

- ① 28 mm thick NBK terracotta tile
- ② BCLP30 Extruded aluminum clip
- ③ HTS30/HTS31 Alum. extruded carrier track
- ④ Extruded Aluminum Angle 6063 T6 2" x 2 1/2" x 3/16" x 0'-8"
- ⑤ Extruded Aluminum Angle 6063 T6 2" x 2 1/2" x 3/16" x 0'-6"
- ⑥ RS30/RS31 "shelf" clip
- ⑦ 1/4"-14 x 1" HWH S.S. Bi-Flex or similar (Not by NBK)
- ⑧ (3) 1/4"-20 x 1" HWH S.S. Bi-Flex or similar (Not by NBK)
- ⑨ 1/4"-14 x 2" HWH S.S. Bi-Flex or approved equal (Not by NBK)
- ⑩ Insulation per design (Not by NBK)
- ⑪ 5/8" GYP. Board sheathing with air & vapor barrier membrane (Not by NBK)
- ⑫ Vertical steel stud framing, min. 16 ga@ 16" centers (Not by NBK)
- ⑬ JTC clip - Anti-walking clip
- ⑭ Aluminum flashing (Not by NBK)

OPTIONAL

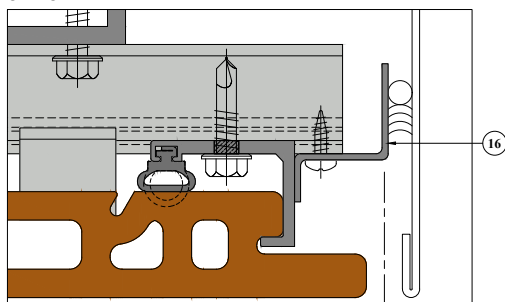

SYSTEM:
TERRART 28

DETAIL:
STANDARD STUDWALL DETAIL

DETAIL NUMBER:
NBK-VS-28-03

TILE DIRECTION:
VERTICAL

DRAWING REFERENCE:
WINDOW JAMB

SCALE:
1:2

NBK | ARCHITECTURAL
TERRACOTTA
A Hunter Douglas Company

NBK North America

10 Federal Street, Second Floor
Salem, MA 01970
Telephone: +1 (781) 639 2662
www.nbkterracotta.com